



GENUINE PARTS

INSTALLATION INSTRUCTIONS

DESCRIPTION: REAR SPOILER KIT
APPLICATION: VERSA NOTE
PART NUMBER: 999J1 4Zxxx (xxx designates color)

KIT CONTENTS:

Item	Qty.	Part Description	Service Part Number
A	1	Spoiler Assembly	999J1 4Zxxx
B	5	Plastic Clips	"Not Available"
C	2	M6 Bolts	"Not Available"
D	1	Grommet Plug	"Not Available"
E	1	Drill Template	999J1 4Z000 T
F	1	Installation Instruction	999J1 4Z000 II

TOOLS REQUIRED:

- Clean shop rags
- Masking tape
- Drop cloth
- Vacuum
- Hammer
- Center punch
- Drill Stop
- Tape measure
- Deburring tool
- Variable speed drill
- Drill bits: 3mm (1/8"), 9mm (23/64"), and 13mm (33/64")
- Hole saw: \varnothing 30mm (1 3/16")
- Torque wrench
- Ratchet with extension
- 10mm deep socket
- Rust preventative (P/N 999MP-9G001P)
- Alcohol solution 90% or greater

PRE-INSTALLATION WARNINGS, CAUTIONS, CRITICAL STEPS, and NOTES:

- Dealer Installation Recommended. Instructions may refer to Service Manual.

WARNING

- Some plastic surfaces may become damaged by alcohol solution. Cover and protect taillight lenses. If alcohol does come into contact with the lens, immediately wash surface with water.
- Failure to clean mounting surface properly may cause tape to have poor adhesion to vehicle.
- If vehicle has been recently painted, allow paint to dry and age 24 hours before installing spoiler.
- Install spoiler when ambient temperature is above 15 C (60 F).
- Do not wash or expose vehicle to a wet environment for 24 hrs. after installing spoiler.
- Please use proper pressure of 103kpa (15lpg) applied with a dry, soft, clean rag to adhere spoiler tape.

INSTALLATION PROCEDURE:

- 1) Apply parking brake.

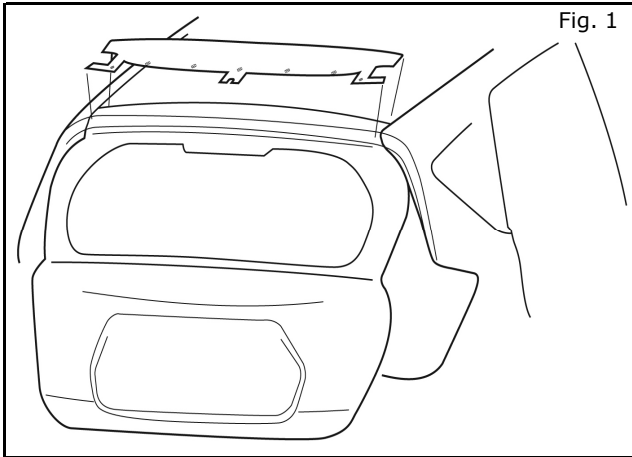

- 2) Position drill templates and drill holes.
 - a) Use the instructions on the drill template to place it on the liftgate. (Fig. 1)
 - b) Tape the template to the liftgate by the tape marks on the template in sequential order.

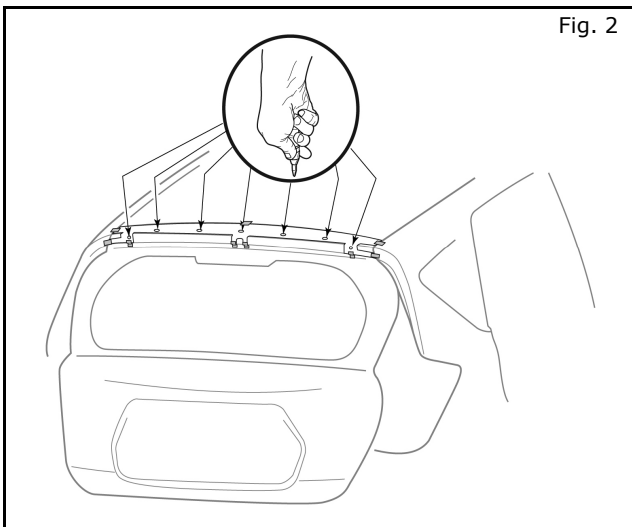

- c) Locate the punch marks in the center of the printed hole locations. (Fig. 2) A light, quick impact on the center punch is recommended to prevent a deep dent on the liftgate. Seven (7) places total.
- d) Remove the drill template from the liftgate.

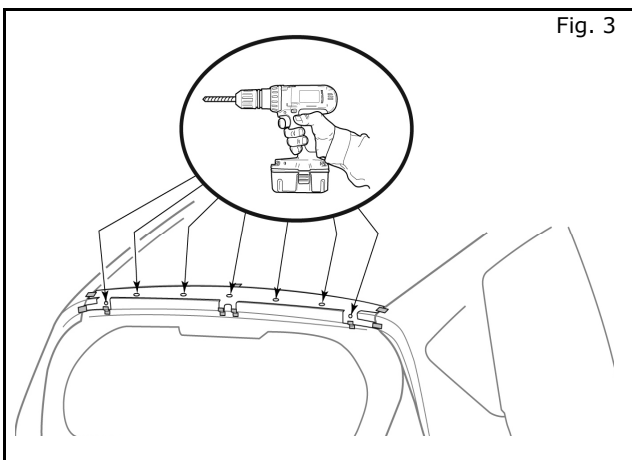

- e) Drill 3mm (1/8") pilot holes at the seven (7) punch mark locations. Drill 9mm (23/64") holes at all seven (7) hole locations. (Fig. 3)
NOTE: Use a drill stop.
- f) Drill the 13mm (33/64") holes at the five (5) locations indicated on the drill template.

(Step 2 Continued)

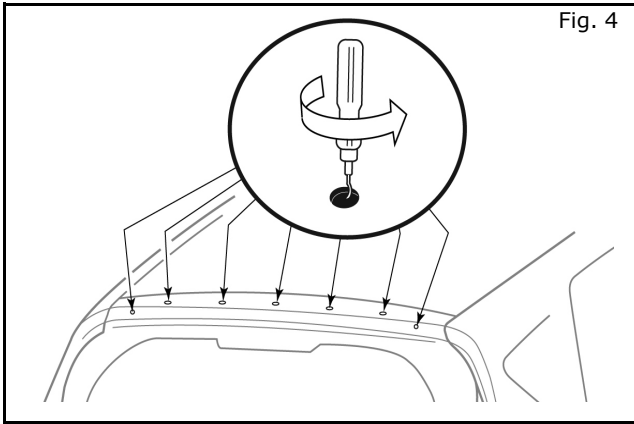

Fig. 4

- g) De-burr the seven holes and remove the metal chips. (Fig. 4)
- h) Apply the rust preventative to the drilled holes.

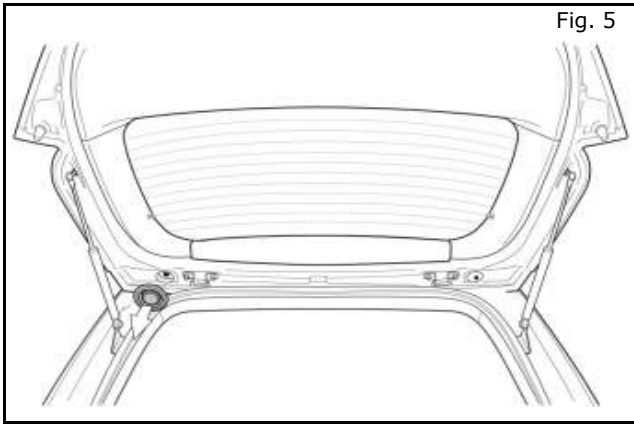

Fig. 5

- i) Open the liftgate and remove the driver side grommet plug shown in Figure 5.
NOTE: Save the grommet plug for later use.

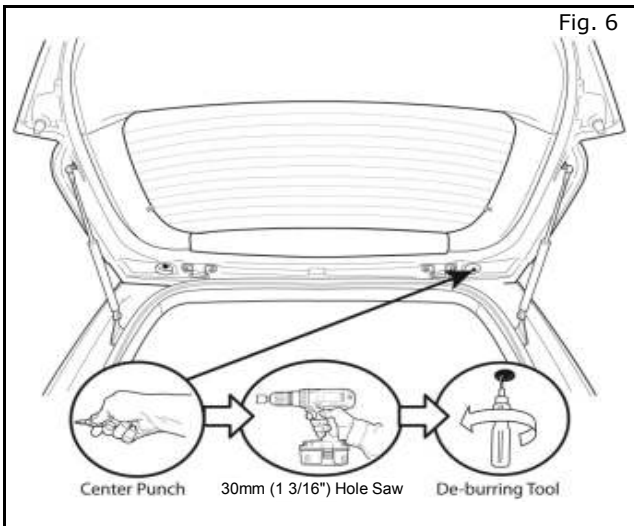

Fig. 6

- j) Cut out paper template on last page of instructions. Use template to locate center of the 30mm access hole on the RH side of the liftgate. Hole should be symmetrical to the existing hole on LH side of liftgate. (Fig. 6)
- k) Place a punch mark for the passenger side access hole. (Fig. 6)
- l) Using the hole saw, drill a 30mm access hole at the punch mark location. (Fig. 6)
- m) De-burr the hole and remove the metal chips. (Fig. 6)
- n) Apply the rust preventative to the drilled hole.
- o) Close liftgate.
NOTE: Allow rust preventative to dry for 5 minutes before proceeding.

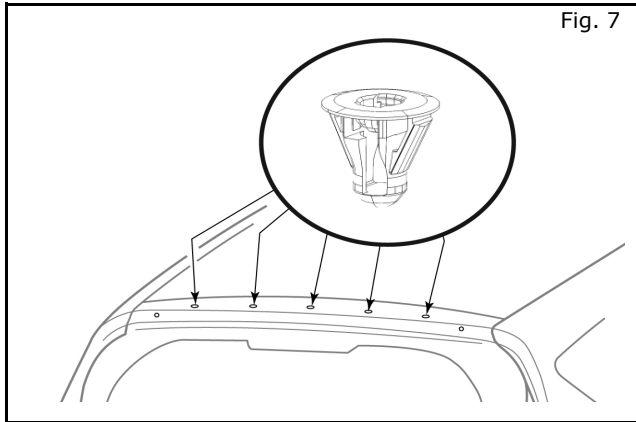

Fig. 7

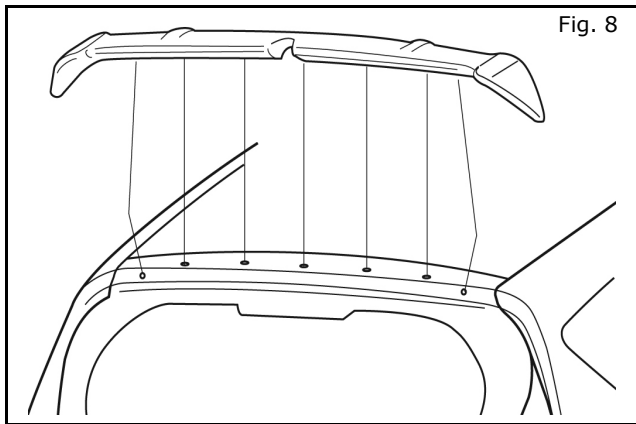

Fig. 8

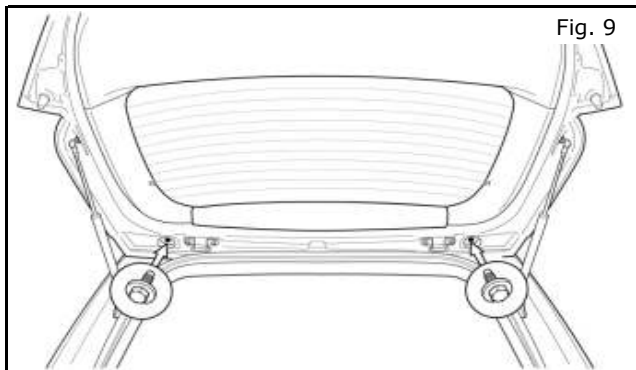

Fig. 9

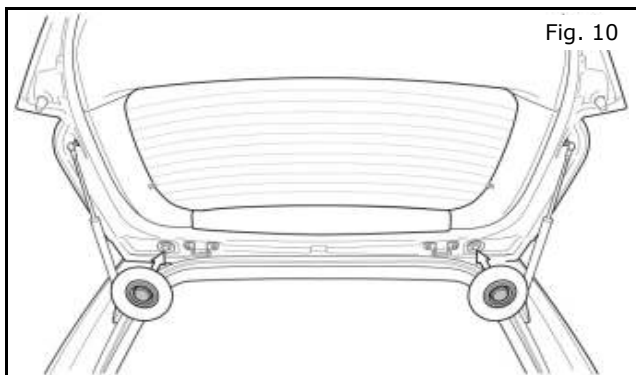

Fig. 10

3) Spoiler Installation.

- a) The surface of the liftgate must be cleaned with alcohol solution 90% or greater for proper tape adhesion.
- b) The trunk temperature should be at least 60°F (15°C) for proper start-up adhesion of the tape. Use a hot air blower if the temperature is below 60°F.
- c) Install the 5 plastic clips into the liftgate in the 13mm holes, 5 places. (Fig. 7)
- d) Carefully place the spoiler on the liftgate. (Fig. 8)
- e) Adjust the 5 sliding studs to the plastic clips. (if necessary)
- f) Before contacting the tape to the liftgate, verify that the spoiler is centered to the liftgate. Remove the tape liners in the following order.
 - 1) One long tape liner on top.
 - 2) Two small tape liners on top.
 - 3) Two long tape liners on bottom.
- g) Using micro fiber cloth apply 15lbs of pressure on the spoiler to adhere the spoiler to the liftgate. Pressure must be applied around entire perimeter of the spoiler.
- h) Install 2 M6 bolts into the u-nut brackets with a 10mm socket tightened to 3.8 N-m (34 inch-lbs.). Do not over torque the bolts. (Fig. 9)
- i) Re-install the driver side grommet plug from step j and install the provided grommet plug in the passenger side access hole. (Fig. 10)
- j) Remove all chips and shavings from vehicle.

ACCESSORY CHECK:

- Check all **torque** values. (Reference related steps and figures)
- Verify all wiring is secure and not exposed.
- Confirm accessory main features and functions including all of its controls, opening and closing mechanism.

ACCESS HOLE TEMPLATE

